

# WZS 70

## Technical Details

### Technical Data WZS 70

<b>Travels of axes</b>	X-axis	740 mm
	Y-axis	250 mm
	Z-axis	740 mm
	B-axis	390° (-180° / +210°)
	C-axis	n x 360°
<b>Resolution</b>	X, Y, Z-axis	0.0001 mm
	B, C-axis	0.0001°
<b>Axis drives</b>	X, Y, Z-axis	2.4 kN
	B-axis	315 Nm
	Rapid travel speeds X / Y / Z	30 / 30 / 30 m/min
<b>Grinding spindle</b>	Motorized spindle	Ø 150 x 300 mm
	Power S7	15 kW / 200 Hz
	Peak power S2	24 kW
	Speed infinitely	1,000 to 9,000 min <sup>-1</sup> / 300 Hz
	Torque const. S7	24 Nm up to 6,000 min <sup>-1</sup>
	Grinding wheel Ø max.	203 mm
<b>Workpiece spindle</b>	Internal taper	HSK 50E (2 sides)
	Internal taper	ISO-50
	Speed standard (optional)	30 (1,200) min <sup>-1</sup>
	Torque max. (optional)	60 Nm (100 Nm)
<b>Machine</b>	Total connected load	15 kVA
	Supply voltage / Frequency	400 V / 50 Hz
	Machine (basic) W x L x H	2,120 x 2,680 x 2,420 mm
	with add. robot W x L x H	3,130 x 2,680 x 2,420 mm
	Weight	approx. 6 t

### Workpiece dimensions (measuring from taper zero line ISO 50)

<b>Manual loading</b>	Ø max.	270 mm
	Length max.	570 mm
	Weight max.	20 kg
<b>Workpiece automation (robot)</b>	Ø max.	32 mm
	Length max.	450 mm
	Weight max.	2.5 kg
<b>Workpiece automation (Pick up)</b>	Ø max.	25 mm
	Length max.	200 mm
	Weight max.	1.5 kg

### Kinematic

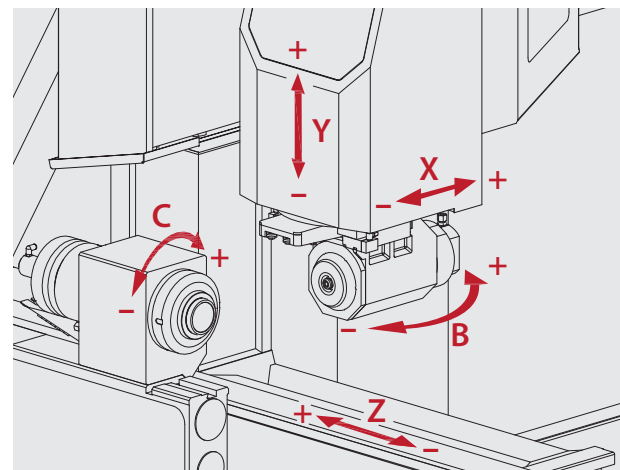

### Dimensions [in mm]

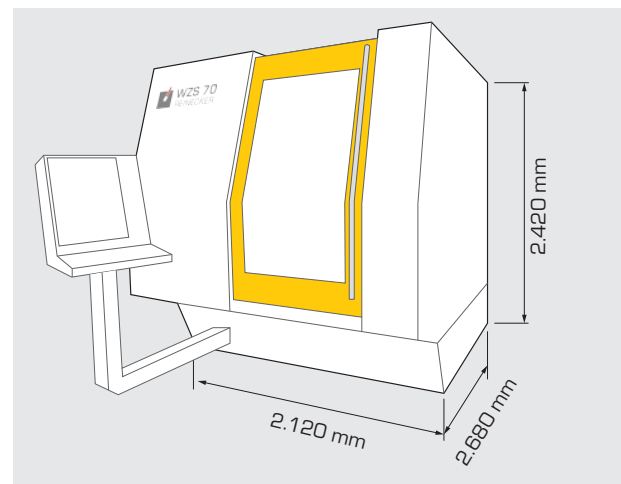

### Ulmer Werkzeugschleiftechnik GmbH & Co.KG

August-Nagel-Str. 9  
89079 Ulm-Eisingen, Germany  
Phone +49(0)7305/171-324  
Fax +49(0)7305/171-328  
info@werkzeugschleifen.de  
www.werkzeugschleifen.de

**ULMER**  
WERKZEUGSCHLEIFTECHNIK